



Support the sponsors who support us - visit http://www.aussieinvader.com/the_sponsors.php



December 2010 - Newsletter

G'day to all our sponsors, supporters and Land Speed Record followers, welcome to our December 2010 newsletter.

I feel like I am driving Aussie Invader 5R already, but it is not the ground flashing past me, but time. Each month holds something good, but life seems to get in the way of LSR attempts. It is nearly the end of the year and we have a motor show in 6 months, with a lot of work to do.

John Ackroyd left us last week and headed back to the Isle of Wight, after doing some extensive design drawings and calculations on Aussie Invader. Working with our team we decided on the final design for the front suspension and steering arrangement. This is yet to have the FEA calculations carried out by our friend Leon Eversfield at Aeromechanics in Wales. Leon's input is vital before we go ahead with the final welding and machining operations needed to complete this very important area of our race car. Mike Annear has completed a schematic drawing of this.

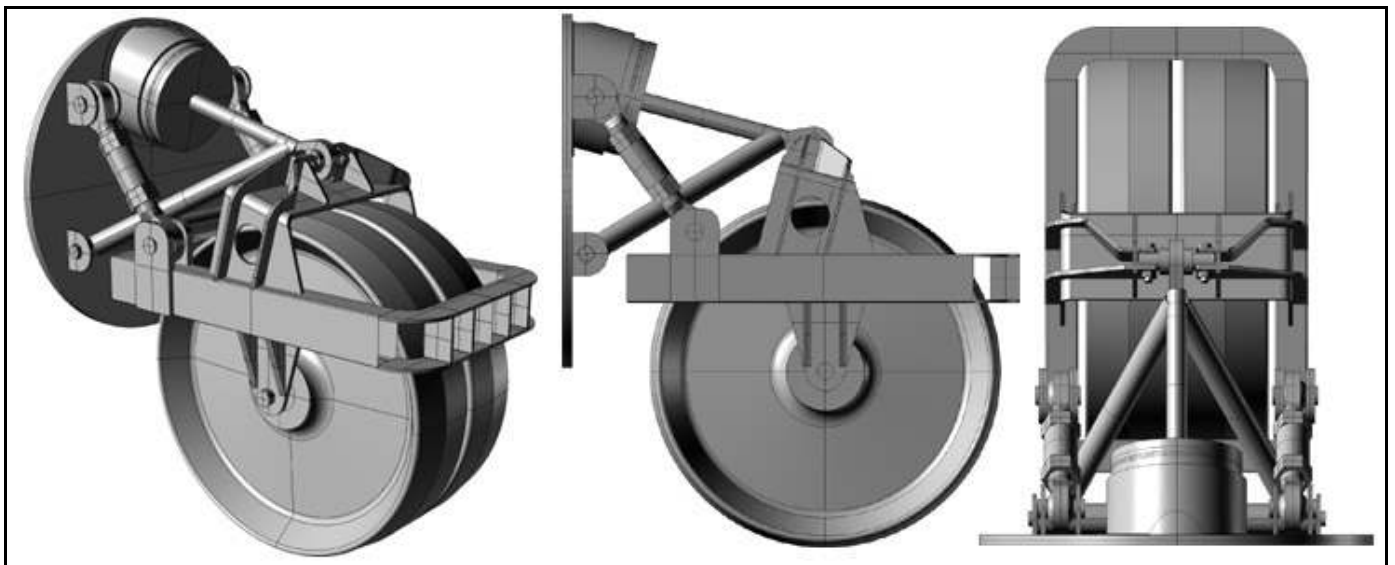



Support the sponsors who support us - visit http://www.aussieinvader.com/the_sponsors.php

Very shortly we are hoping to post a video of its operation, which will explain how it all works, because even for some very experienced engineers is not immediately obvious from diagrams.

Recently I have been asked to do a lot of motivational talks, which does help in promoting what we are doing, but takes a lot of my time. We have had quite a few sponsor meetings thrown into the mix also, but this increase in activity hopefully means our message is getting out there and that this car and the record runs could be bigger than King-Kong. The race with the Americans, and the Brits is adding to the exposure for all teams and sponsors are starting to wake up to the idea that this is going to be big, certainly bigger than any previous record attempt I have been involved in. On that note, things are coming together nicely with Alex Blain in talks with a well known documentary maker for 4 x 1 hour episodes about the project... more soon!



One such motivational talk I was asked to perform was for the Cancer Council by our late and sadly missed team member Dougie

<http://www.cancerwa.asn.au/> McKay before his passing last year. This I did a couple of weeks ago on a lunchtime meeting with these lovely folk, what a great day with the majority of people asking one question "why would you want to set your record in Nevada, USA instead of Western Australia?"



Rosco giving a talk for the Cancer Council in Perth

I explain to people that to find a new location requires a large amount time, effort and cost with research, logistical support and surveying equipment. Then you need government support to help with the permits and approvals required. It is much more cost effective to pack our car into a 40' shipping container and take her across to California then via road transport to Nevada.

Since the Cancer Council talk we have had a lot of feedback from various people offering their support if we can run our race in our home state, which for interest, WA is seven times larger than Texas. If you have seen the movie Australia you will have seen some of the desert playa we are looking at in the North West Kimberley and we will keep you updated on any developments. If there are any WA mining companies with surveying resources that want to help, please get in touch with us?

One last point on this subject is that we may only need a shortened track in WA (up to 20km) we can use this to test the car, before trekking long distances, but who knows, if we find the right piece of dirt we could run it properly in WA.





Support the sponsors who support us - visit http://www.aussieinvader.com/the_sponsors.php

One of our crew, Mike Annear is a keen paraglider and is often travelling around the world. When he gets a spare moment, up he goes. This is great for us as he often looks for potential places to race our car. Here are just a few shots of WA wide open spaces.



Views of WA by Mike Annear from his paraglider – view more at http://www.mikeannear.com/PG_australia.html

The Team and Sponsors BBQ

Whilst John Ackroyd was here we thought it would be the perfect time to have a team and sponsor's get together, so we sent out invites to all the companies and individuals who have helped us get to this stage of our cars development.

The evening BBQ was a huge success with a guest list of over 70 people and the night's festivities were well catered for with great food and wine by our newly found sponsors Mondo Meats (<http://www.mondo.net.au/>) and Sandalford Winery (<http://www.sandalford.com/>) with lots of arranging performed by Alex Blain and Loco TV (<http://www.locotv.com.au/>).



For more images of the BBQ visit http://www.aussieinvader.com/attachments/Image/Latest_News/bbq_montage.jpg





Support the sponsors who support us - visit http://www.aussieinvader.com/the_sponsors.php



Poster design by Katie Beese - <http://www.katiebeese.com>

The BBQ was also a chance to show some new samples of our caps and t-shirts and reveal our Aussie



<http://www.scott.com.au>

Invader poster which was kindly printed by Scott Print. Mike Annear donated one of his great images of the car and the poster was created by Katie Beese. Thanks for all the people who made this happen. There is an initial run of 1000 posters, most of which are going to be signed by me and will go to sponsors as a thank you for their great support. Again special thanks to Mark Read and Alex Blain for making this happen.



Alcoa have been a great supporter of my Land Speed Record mission for several years and again this year asked me to be their after dinner speaker at their Apprentice Awards Night.

What a great night it turned out to be, mixing with some really talented and motivated young people ready to take on the world.

Good luck and best wishes to you all.



Speaking at the Alcoa Apprentice Awards Night





Support the sponsors who support us - visit http://www.aussieinvader.com/the_sponsors.php

You may have noticed that Mark Read has changed the website, there were several reasons for this, but hopefully you like it. Several of the menu items have been condensed but everything that was there still exists. Several of the pages are due for a serious rewrite, in light of the changes to the rocket configuration, but that will need to wait until we have more information.

In the meantime, do check out the websites' new look and feel - <http://www.aussieinvader.com>

It is that festive season again and with me desperately trying to be an extreme achiever, I dread this time of year. In Australia two weeks into December through to mid February virtually every business is either shut or on go slow with staff on vacation or relying on support from other companies who are in the same mode to manage their workload.

Trying to build the world's most powerful and hopefully fastest car does not take into account time off for Christmas, but speaking of Christmas, the entire Aussie Invader Team would like to take this opportunity to wish you and yours all the very best for Christmas and the New Year, we hope that 2011 will be a real blast for you all and that Santa brings you some goodies.

Until our next newsletter, be your very best,

Rosco McGlashan OAM
Fastest Aussie on Earth

If you wish to be removed from this newsletter, please reply to rosco@aussieinvader.com with remove in the subject line.

